

NEW WAREHOUSE PANELS

BUILT TO GO BIG FOR XL PROJECTS



Built for Scale and Efficiency

AmeriKooler's EPS Core Insulated Metal Panels offer an ideal solution for expansive warehouse applications. Engineered for durability and ease of installation, these panels are the ultimate choice for large-scale projects that prioritize efficiency, strength, and reduced construction timelines. Constructed to maximize spans and heights, AmeriKooler panels streamline the build of vast warehouse environments without sacrificing quality or insulation.

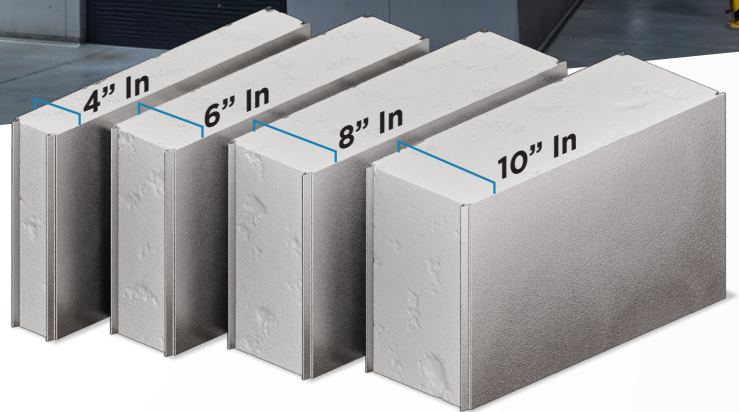

FEATURED SPECIFICATIONS

Panel Dimensions:

- Thickness Options: 4", 6", 8", or 10"
- Maximum Height: 32 ft (varies with panel thickness)
- Standard Panel Width: approx. 45"

Panel Characteristics

- R-Values at 75°F: 16 at 4" thick to 24 at 6" thick
 - (ASTM CR518)
- Density: .90 lbs./ft³. (4" thick) to 1.35 lbs./ft³ (6" thick)
 - (ASTM D1622)
- Polyurethane, CFC-free adhesive lamination
- Flame Spread Index = 0
 - (ASTM E84)
- Smoke Development Index = 190
 - (ASTM E84)

(Values Reported by NOA No. 21-1228.07 as of 02/1/2022)

Panel Finishes

- Available in standard Acrylume, Smooth, or Corrugated Finish
- Available with Acrylic Coat finish in Black or White

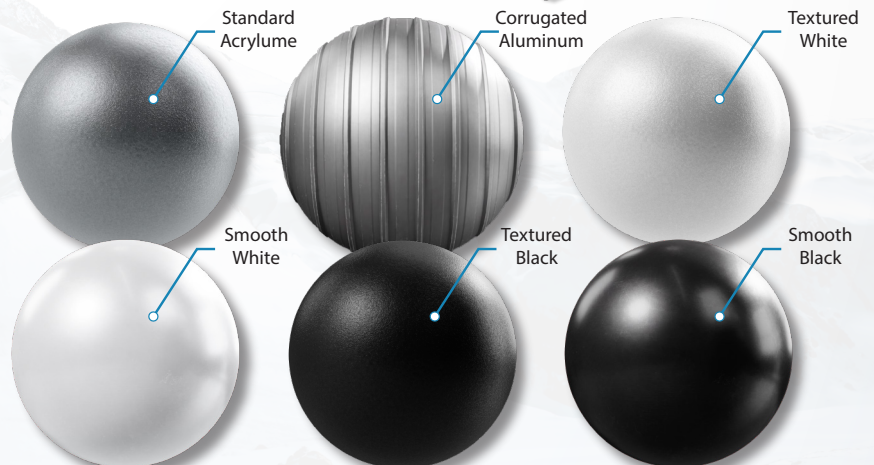

EASY TO DO BUSINESS WITH SINCE 1985

V10.29.24

NEW WAREHOUSE PANELS

BUILT TO GO BIG FOR XL PROJECTS



Easy Installation - Great Performance

Features an interlocking tongue and groove joint for a secure, foam-to-foam connection that minimizes thermal breaks and reduces installation time. These panels are engineered to exceed performance expectations across industries, providing a reliable and energy-efficient solution.

IDEAL FOR A RANGE OF ENVIRONMENTS

A versatile option ideal for a variety of applications, including product distribution warehouses, food processing facilities, controlled environment rooms, mechanical and horticultural spaces, clean rooms, plasma banks and more. AK warehouse panels provide reliable insulation and structural durability for the largest jobs.



Distribution Warehouses



Environment Rooms



Food Processing

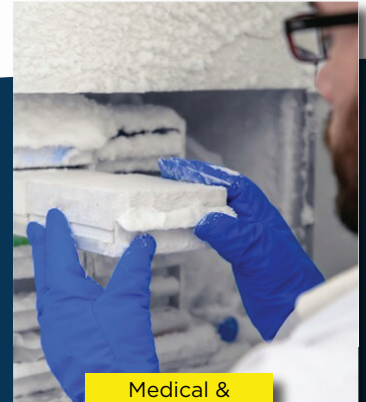

Medical & Laboratory

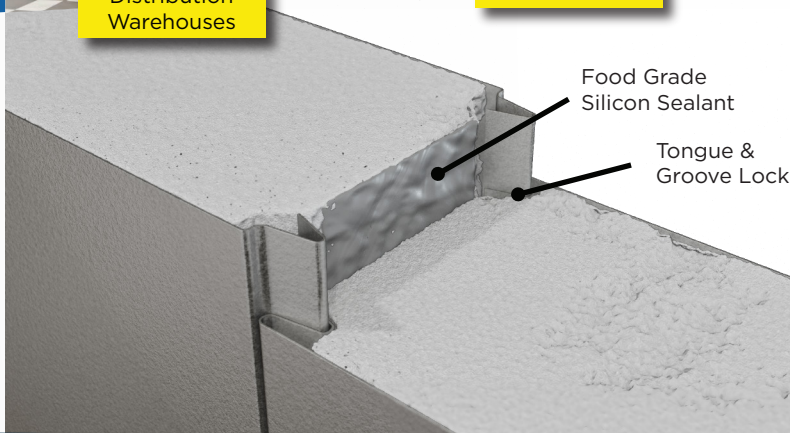

Food Grade Silicon Sealant

Tongue & Groove Lock

TONGUE-AND-GROOVE PANEL LOCKING SYSTEM

Engineered to deliver superior airtight sealing and reliable strength for warehouse refrigeration solutions. Unlike conventional AK camlock systems, our tongue-and-groove panels are to be secured with a durable silicone sealant between each panel at the job site, forming an uninterrupted airtight barrier to maintain precise temperature control.

- Each panel is crafted with precision-fit edges and reinforced by stainless steel angel brackets at corners and edges, delivering unmatched durability and a sleek finish.

Important Note:

Panels are shipped without pre-made openings for maximum design flexibility—openings to be cut on-site.

THINK BIG. BUILD BIGGER.

IDEAL FOR A RANGE OF ENVIRONMENTS

- With each panel custom-built to order, AmeriKooler guarantees unmatched quality and customization.

- Whether constructing a 100,000-square-foot facility or a controlled environment room, AmeriKooler's EPS Core panels deliver on scale, energy efficiency, and enduring performance.

For more information, detailed span charts, or to discuss your project, contact AmeriKooler today and let us help you build the perfect solution.



EASY TO DO BUSINESS WITH SINCE 1985

V10.29.24

1.800.627.5665

575 East 10th Avenue, Hialeah Florida 33010 USA

www.amerikooler.com